

Mobile lifting solutions that improve your working environment manufactured in Sweden

Electric battery operated mobile lifting solutions with tools, adapted to your needs.



Lift trolleys to be able to handle, lift and rotate various goods in a safe, efficient and ergonomic way. The lift trolleys are divided into five different series, **PRX**, **P**, **DC**, **IE** and **E**, and they offer a lot of customization options.

The PRX and P trolleys are the most flexible and prepared for customer adaptations. We offer a wide product range and there is a large number of standard tools.

The lift trolleys are usually electrically battery powered, with the exception of ATEX environments. They are user-friendly and require very little service and maintenance. The lifting column has a screw drive, which makes the trolleys very reliable and durable for many years of use.

All lifting trolleys have a built-in release function that acts as a tipping and crushing protection. The function automatically disengages the lowering movement if the load is obstructed during lowering.

All lift trolleys are available in painted and stainless steel versions as well as in ESD versions.



The lift trolleys are CE-marked. 

PRX-lift trolleys for load capacities up to 225 kg

Our completely modular family member, a unique, modular concept forms the basis of our PRX-trolleys, giving you and us virtually unlimited opportunities to create a lifter which is perfectly suited to your needs. We offer chassis of variable widths, heights and lengths as well as custom made ones. Personalise your lift trolley to meet the handling requirements in your premises.

The load capacities are **90 kg, 130 kg, 175 kg and 225 kg.**

All this with the best ratio between own weight and load weight.

The lifting columns can be supplied in different standard heights, but can also be custom made to provide the exact desired stroke. As an alternative we also offer a telescopic lifting column that enables you to double the lifting height. In order to best adapt the trolley to the particular needs of different working environments, we provide wheels in various sizes and materials. In addition to the central brake, the PRX-trolleys also have a directional lock on the rear wheels.

PRX lift trolleys are modularly constructed; customize the lifting cart to fit your needs!



The range of models offer many different possibilities because they can be customized. So you can get a trolley that meets your needs perfectly.

Increase your productivity with PRX

User-friendly and easy to maintain

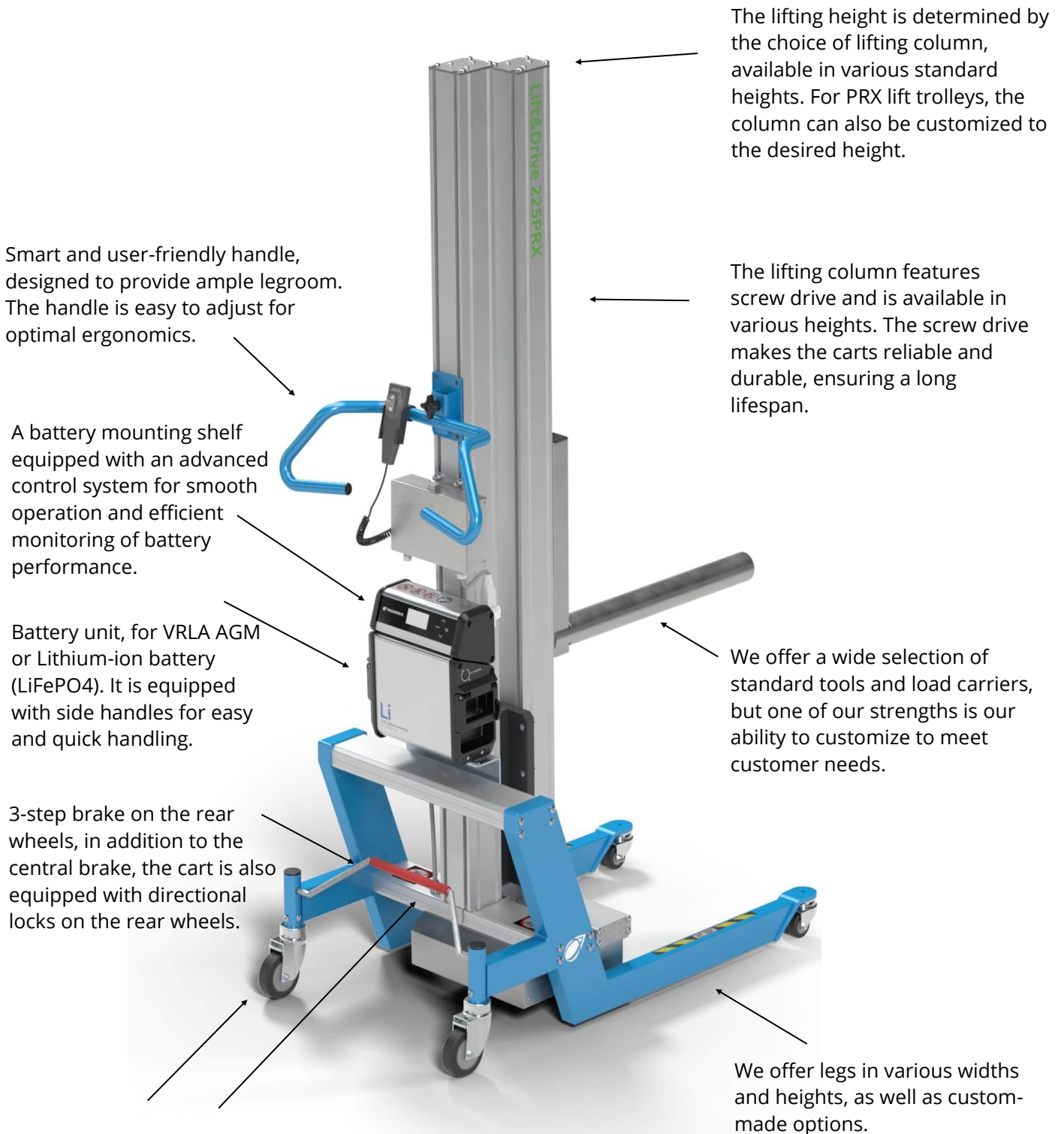

The lifting height is determined by the choice of lifting column, available in various standard heights. For PRX lift trolleys, the column can also be customized to the desired height.

The lifting column features screw drive and is available in various heights. The screw drive makes the carts reliable and durable, ensuring a long lifespan.

Smart and user-friendly handle, designed to provide ample legroom. The handle is easy to adjust for optimal ergonomics.

A battery mounting shelf equipped with an advanced control system for smooth operation and efficient monitoring of battery performance.

Battery unit, for VRLA AGM or Lithium-ion battery (LiFePO4). It is equipped with side handles for easy and quick handling.

We offer a wide selection of standard tools and load carriers, but one of our strengths is our ability to customize to meet customer needs.

3-step brake on the rear wheels, in addition to the central brake, the cart is also equipped with directional locks on the rear wheels.

We offer legs in various widths and heights, as well as custom-made options.

The lift trolleys have 4 swivel casters, of which the 2 rear ones have a central brake and directional lock. The four swivel casters allow for precise positioning of the lift for precision lifting.

We can offer various wheels in different sizes and materials.

325P - the ultimate lifting trolley for impressive load handling up to 325 kg

The 325P lift trolleys pushes the boundaries of what's possible. With an impressive capacity, it smoothly handles various loads up to 325 kg and is tailored for each unique task.

The 325P offers nearly limitless configuration options to create a lifting solution completely tailored to your needs. Choose from various standard heights of the lifting columns or request a custom-made version. Customize the wheels to your requirements with options such as fixed wheels or low-profile wheels.

We go the extra mile by offering customer-specific lifting tools tailored to perfectly complement the 325P according to your needs.

Equipped with a central brake and an innovative 3-step brake that acts as a directional lock on the rear wheels, the 325P lift trolleys is exceptionally easy to handle.

Modular and flexible - the 325P is fully customizable to meet your unique needs.



All lift trolleys are equipped with a built-in disengagement function that acts as a tip and pinch protection. The function automatically disengages the lowering movement if the load is obstructed during descent.

The 325P is versatile and can be assembled according to requirements

1. The legs are available in various lengths and widths.
2. Power pack
3. Control box
4. Control box holder
5. Lift column with screw drive
6. Cross member available in various widths
7. Central brake with directional lock
8. Handle, easily adjustable to the correct height



5. Lift column with screw drive

3. Control box +
4. Holder

8. Handle

2. Power pack

6. Cross member

1. Legs

7. Central brake

A selection of tools for the PRX and P lift trolleys

We have a large number of standard tools such as loading platforms, forks, scales clamping tool and our pneumatic expander, intended for handling reels when you need to lift/rotate from the core.

We also manufacture many customer-specific tools.



Pneumatic expander, lifts at the center, it's expandable 360°.



Platform with V-block, combined with the rotating disk, rotates the V-block so that the roller can be positioned correctly.



Lifting boom - simple and perfect for handling horizontal rolls. Available in various sizes.



Scale platform with counting and control functions.



Load platform with edge rollers, edge rollers can be on one to three sides.



Roller platform with locking, available with both side and front loading.



Customized clamping tool with tipping function.



Lifting fork that can be customized as needed.



Customized clamping tool that can be rotated 360°.

DC - Lift trolleys for efficient handling of server and battery systems

For safe, ergonomic, and efficient handling that can be performed by one person

With a server and battery lift trolley you not only streamline the work but also reduce the risk of personal injuries and equipment damage in the data center. Manual lifting and moving of server units and batteries pose a significant risk in the work environment. These units are not only heavy, requiring two or more employees for handling, but they are also costly and susceptible to damage in case of falls.

By integrating a server and battery lift trolleys, handling becomes safe, efficient, and transformed into an ergonomically favorable task for a single person. The lift trolleys are designed for ease of maneuverability, even in tight aisles, thanks to their compact and lightweight design with minimal turning radius.

With precise and stepless control over the load platform, the specially designed load platforms easily reach from the lowest rack units to the highest positions. This enables smooth assembly and removal of servers and batteries. Since each data center has its unique needs, we offer lift trolleys built on a modular concept. The modular concept provides you with the flexibility to create your ideal lift trolley by choosing the components and accessories that best suit your facility.



The lift trolleys are available with a maximum lifting capacity of 150 kg.

All lift trolleys are equipped with a built-in disengagement function that acts as tip and pinch protection. The function automatically disengages the lowering movement if the load is obstructed during descent.

DC Lift trolleys for handling servers and batteries

Overload protection

Prevents handling of excessively heavy loads. This eliminates the risk of injury to both personnel and equipment due to overload.

Telescopic lifting column

Enables maneuvering through low door openings while reaching high. Increased lifting speed.

Different platforms for different needs

Sliding platform to bridge the gap between the lift trolley and the server +/-150mm.

Fixed platform for easy handling.

Rechargeable batteries

The lifting motion is powered by rechargeable batteries.

Adjustable handle

Easy adjustment to fit the current user best. Reduces strain on muscles and joints.

Movable hand control holder

To accommodate both left- and right handed users.

Stepless control

With the removable stepless hand control, you lift and lower with precision.



3-step brake

Foot-operated central brake with directional lock for easy straight ahead driving, preventing swiveling.

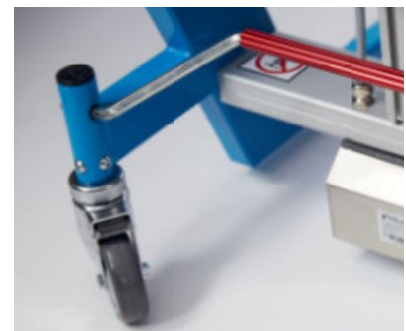

Swivel wheels

The maneuvering becomes stable and comfortable even in tight spaces.

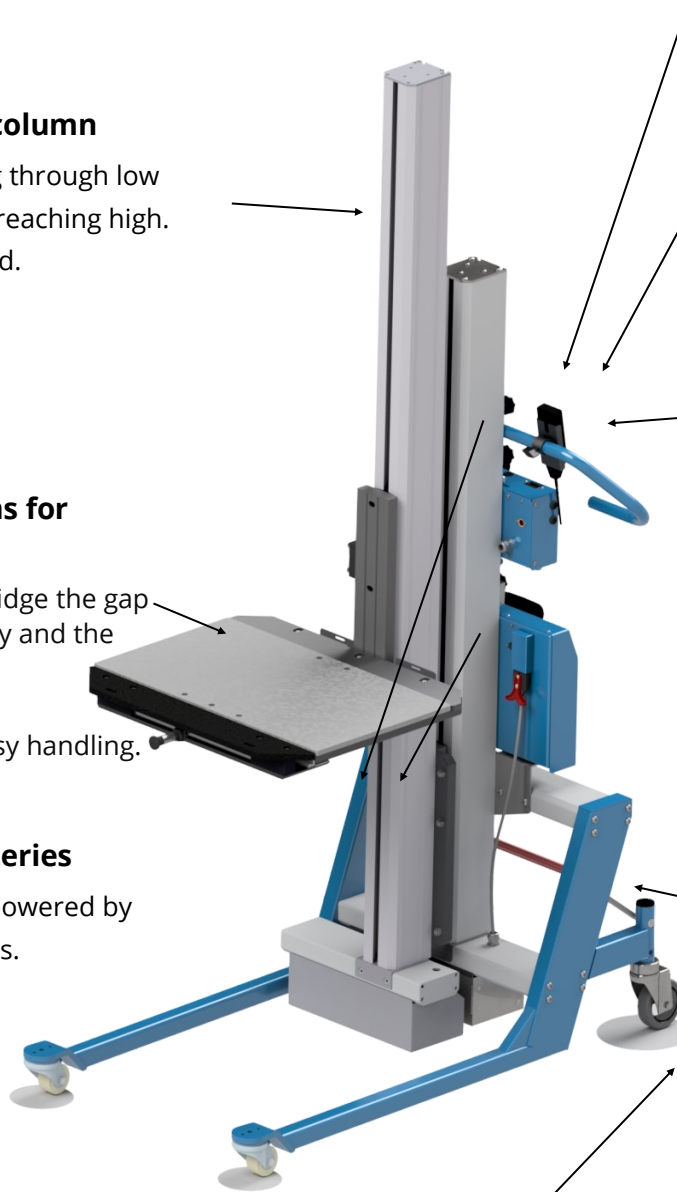

90IE stable and efficient lifting trolley for handling weights up to 90 kg

These are stable, manoeuvrable lift trolleys with a low weight, which can be equipped with a number of different tools. 90IE is adapted to and ideal for personnel with frequent goods handling. The lift trolleys is flexible and stable and very user-friendly, the durable quality construction demands minimal maintenance. This chassis outside width is only 555 mm.

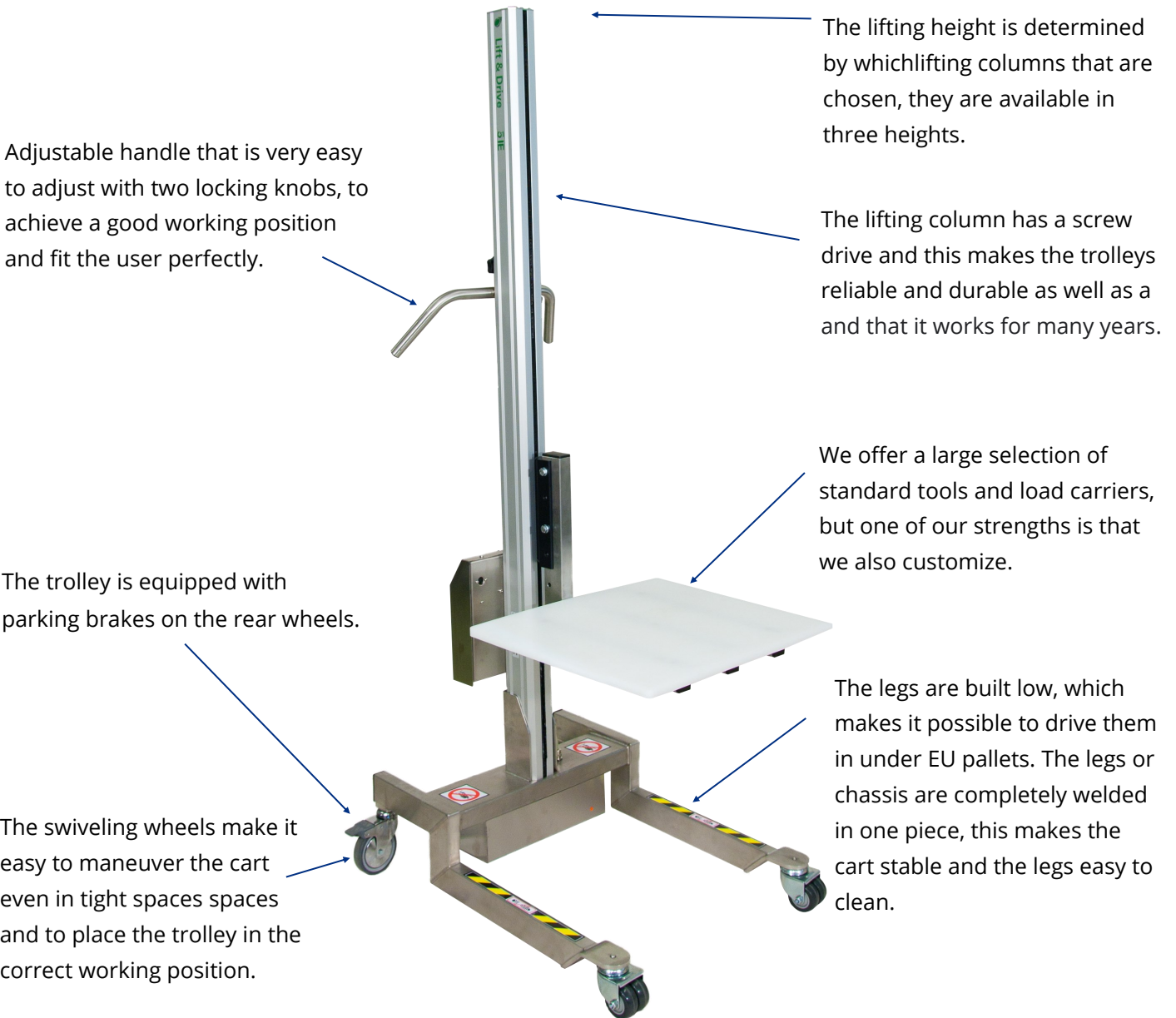

Adjustable handle that is very easy to adjust with two locking knobs, to achieve a good working position and fit the user perfectly.

The lifting height is determined by which lifting columns that are chosen, they are available in three heights.

The lifting column has a screw drive and this makes the trolleys reliable and durable as well as a and that it works for many years.

We offer a large selection of standard tools and load carriers, but one of our strengths is that we also customize.

The trolley is equipped with parking brakes on the rear wheels.

The legs are built low, which makes it possible to drive them in under EU pallets. The legs or chassis are completely welded in one piece, this makes the cart stable and the legs easy to clean.

The swiveling wheels make it easy to maneuver the cart even in tight spaces spaces and to place the trolley in the correct working position.

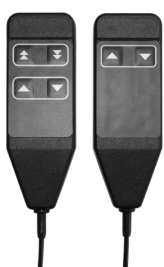

The tools are raised and lowered with a control box. The control boxes are available in two variants, with two or four buttons. Four buttons for slow maneuvering.

The control boxes are detachable from their holder on the handle, this makes it possible to raise and lower the tool even when the work is carried out in front of or on the sides of the lifting trolley.

90IE is available in painted and stainless steel versions as well as in ESD



Some of our standard accessories for the IE lift trolleys

There are a large number of standard tools, loading platforms, V-blocks, lifting booms, and a manual expander, but one of our major advantages is that we also create custom accessories. The tools are adjustable, operated by rechargeable batteries.



Loading platform made of polyurethane plastic.



Loading platform protection in stainless steel.



Loading platform with edge rollers, the edge rollers can be placed on desired sides.



Platform with V-block, combined with the turntable, rotates the V-block so that the roller can be positioned correctly.



Roller platform with side feeding, with locking.



Roller platform with front feeding, with locking.



Lifting boom for handling horizontal rolls.



Manual expander for lifting and rotating small rolls within the core.

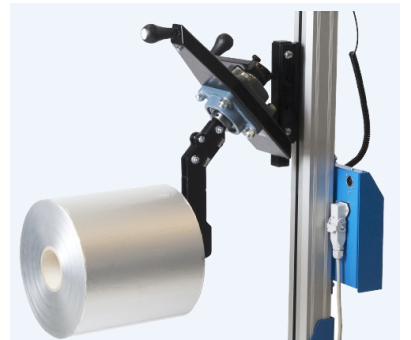

Manual expander for lifting and rotating small rolls within the core.



Forklift that can be customized as needed.



Control boxes with two or four buttons for different speeds



Ladder that is foldable.

70E and 90E are our light weight and slim lift trolleys in load capacities of 70 and 90 kg

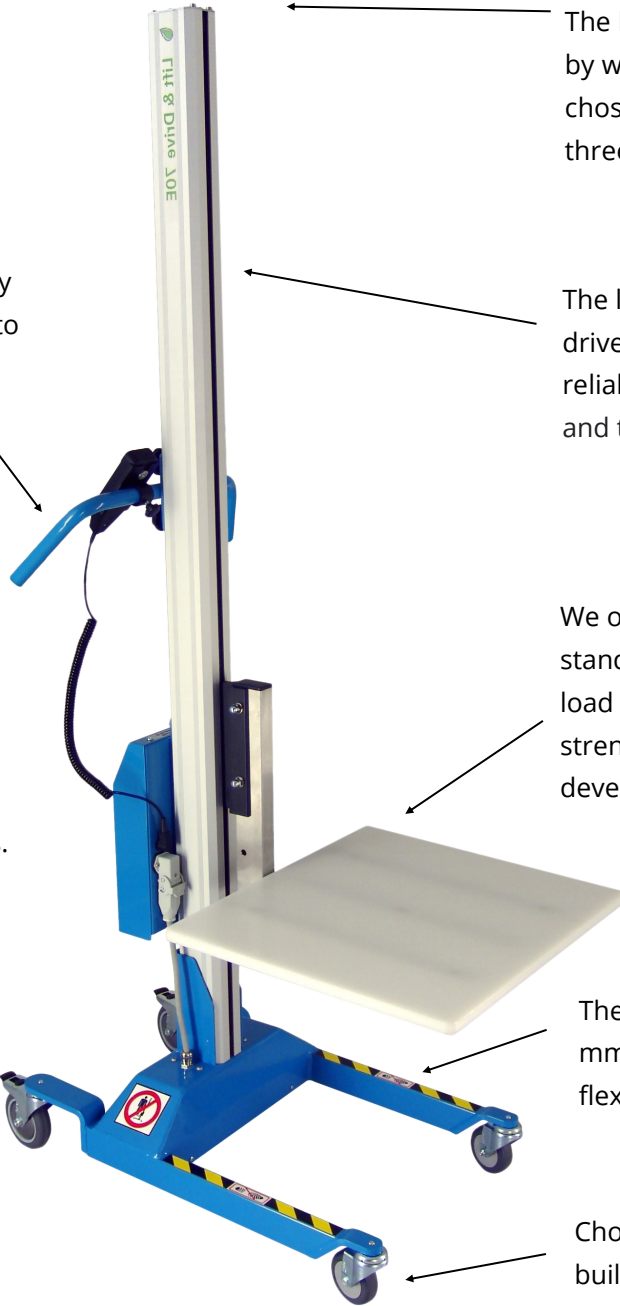

The lifting height is determined by which lifting columns that are chosen, they are available in three heights.

The lifting column has a screw drive and this makes the trolleys reliable and durable as well as a and that it works for many years.

We offer a large number of standard tools, lifting forks and load carriers, but one of our strengths is that we have also developed special tools.

The legs or chassis are only 435 mm wide, which makes it very flexible and manoeuvrable.

Choose from standar or low-built wheels to adapt the trolley to your working environment.

Adjustable handle that is very easy to adjust with two locking knobs, to achieve a good working position and fit the user perfectly.

The trolley is equipped with parking brakes on the rear wheels.

The swiveling wheels make it easy to maneuver the cart even in tight spaces spaces and to place the trolley in the correct working position.

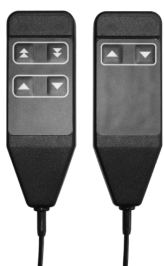

The tools are raised and lowered with a control box. The control boxes are available in two variants, with two or four buttons. Four buttons for slow maneuvering.

The control boxes are detachable from their holder on the handle, this makes it possible to raise and lower the tool even when the work is carried out in front of or on the sides of the lifting trolley.



70 and 90E are available in painted and stainless steel versions as well as in ESD versions.

Some of our standard tools and accessories for 70 and 90E

There is a large number of standard tools, loading platforms, V-blocks, prong, and a manual expander, but one of our major advantages is that we also create custom accessories. The tools are adjustable in height, powered by rechargeable batteries.

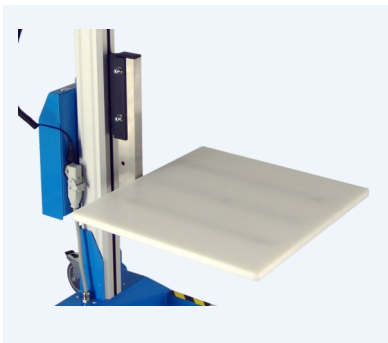

Load platform in standard size 498x440mm.



Stainless steel protective plate for our platform.



Platform with V-block, combined with the turntable, rotates the V-block so that the roller can be positioned correctly.



Forklift that can be customized as needed, here with a foldable pallet tray.



Lifting boom for handling horizontal rolls.
L=500mm, Ø 60,3mm



Folding ladder.

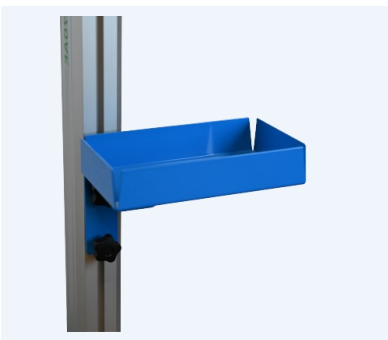

Storage shelf that mounts on the column.

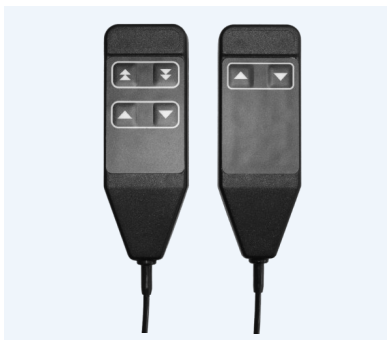

Control boxes with two or four buttons for different speeds.



Battery charger and holder for the charger.



Tool **Some of our other tools**



Products **Some of our other products**



For over 20 years, we have been creating customer-specific **special solutions**

We want our products to make a real difference.

To achieve an optimal solution, it often requires us to develop customer-specific special solutions. Since we have a lot of basic components to work from, it may sometimes involve making minor adaptations to existing products. However, quite often, a customized special solution is needed. In such cases, we design and manufacture a solution that we hope will be properly utilized and appreciated.